

1295ELT HANDBOOK

Lycian Stage Lighting

**1144, Kings Highway
PO Box 214
Sugar Loaf. NY 10981
USA**

USA voice: 845-469-2285

USA Fax: 845-469-5355

e-mail: info@lycian.com

Website: www.lycian.com

Instructions for Model 1295ELT 3KW and 4KW Xenon Follow spot.

Setting up, lamping and operating.

SETUP

The 1295 follow spot comes in three parts: the head assembly, the base/yoke assembly and an electronic power supply. There are two different bases available. The 1322 is a folding base that has three legs and a tie down for the ballast and then there is the 1323 rigid base that is for permanent installations which has four legs and has leveling jacks and a plate for the ballast to fit into and locked onto the base. There are heavy duty locking casters that are available for either base which is part #46.

To begin setup, place the base in the intended location and level the base using the leveling jacks if so equipped. The electronic ballast should be oriented such that the ballast is accessible by the operator. If the follow spot is to be permanently mounted, bolt the base to the platform using caster foot assembly #46X. Safety cables should be used if the follow spot is mounted above floor level. The yoke assembly can be raised up to six inches via the vertical holding pin.

To place the head assembly into the yoke, ensure that the bearing retainers are open and the brake handle is loose so the disc can fit in between the brake shoes. These retainers are at the top of each yoke post. Slacken the locking screw and rotate the bearing retainer.

Lift the head up and into the yoke so that the yoke bracket bearings nest in the ends of the yoke, ensuring that the brake disk fits within the brake shoes on the operator's side of the yoke.

Close the bearing retainers and tighten the locking screws. Tighten the tilt brake knob located on the operator's side of the yoke upright.

The electronic ballast sits into the tray between two legs on the 1323 base. There is a hinged strap on the base that connects to a bracket on the rear of the ballast using a pin. This prevents the ballast from tipping over.

Connect the lamp supply leads to the fixture. ENSURE WITHOUT QUESTION that the red cable socket is connected to the red plug on the fixture, and the black cable socket is connected to the black plug on the fixture. Reversal of these connectors will result in destruction of the xenon lamp within 30 seconds if power is applied.

The input power lead must be connected to an appropriate supply in the next section.

ELECTRICAL CONNECTION.

Input requirements.

The electrical supply shall be capable of delivering 4KW.

Input voltage range --- 200V to 250V AC 50/60Hz.

Input current at 200V is 23A for a 3KW lamp

Input current at 250V is 17A for a 3KW lamp

Input current at 200V is 32A for a 4KW lamp

Input current at 250V is 26A for a 4KW lamp

A 30A supply capability is recommended when used at this supply voltage range for a 3KW lamp and a 40A supply capability is recommended when used at this supply voltage range for a 4KW lamp. However, the supply cable to the follow spot should be rated such that the voltage drop from the supply source and the follow spot connection shall not exceed 2%.

IE at 208V the voltage drop should not exceed 4V when the fixture is operating.

The fixture has a three line supply cord with the following color code.

Green/Yellow stripe - Ground or earth.

Blue – Neutral

Brown - Live

The line cord fitted is H07RN-F 3G6, 6mm² rated at 32A.

This is equivalent to American wire size 10AWG.

When used with a three-phase system the blue neutral wire may be used as one of the hot legs.

IMPORTANT - THE FIXTURE MUST BE GROUNDED.

****** CAUTION *** WARNINGS *** CAUTION **** WARNINGS**

DO NOT HANDLE THE XENON LAMP WITHOUT PROTECTIVE CLOTHING, FACE MASK AND GLOVES.

**EXPLOSION HAZARD EXISTS AS LAMP IS HIGHLY PRESSURIZED.
OBSERVE ALL HANDLING INSTRUCTIONS PROVIDED
BY THE LAMP MANUFACTURER.**

**ONLY TRAINED PERSONNEL FAMILIAR WITH HANDLING XENON LAMPS
SHOULD PERFORM LAMPING / DE-LAMPING AND GENERAL LAMPHOUSE
MAINTENANCE.**

**THE LAMP MUST BE CHANGED IF IT HAS BECOME
DAMAGED OR THERMALLY DEFORMED.**

**SHIELDS, LENSES OR ULTRAVIOLET SCREENS MUST BE CHANGED IF THEY
HAVE BECOME VISIBLY DAMAGED TO SUCH AN EXTENT THAT THEIR
EFFECTIVENESS IS IMPAIRED BY CRACKS OR DEEP SCRATCHES.**

**DISTANCE FROM THE FIXTURE TO LIGHTED OBJECTS MUST BE GREATER
THAN 15 METRES (50FT) TO AVOID POSSIBLE COMBUSTION**

**KEEP ALL COMBUSTABLE MATERIAL GREATER THAN 1 METER FROM THE
FIXTURE**

LAMP SPECIFICATIONS

The correct lamp for this fixture is a 3KW or 4KW short-arc discharge lamp with a xenon gas filled envelope.

The lamp voltage for the 3KW is 29V DC and requires a current of 100A maximum which is provided by the electronic ballast for the fixture.

The lamp voltage for the 4KW is 28V DC and requires a current of 135A.

The anode (+) terminal is 9.5mm diameter with a cable attached for connection to the igniter. The cathode (-) terminal is 8.0mm diameter.

The overall length of the 3KW lamp is 342mm, with a globe diameter of 60mm and the overall length of the 4KW lamp is 410mm with a globe diameter of 70mm.

The 3KW lamp has a suggested life expectancy of 2200 hours and the 4KW lamp has a life expectancy of 1500 hours. The lamp light output diminishes with age as the inside of the globe blackens and therefore the lamp maybe replaced earlier to maintain high output levels. The lamp should be rotated along its length after you've reached half the lamps life so that the top blackened area is at the bottom, avoiding blackening in one spot.

The recommended manufacturers of suitable lamps are:

Osram XBO 3000 W/HS XL OFR and XBO 4000 W/HS XL OFR

Yumex YXL 30SC and YXL 40SC

Ushio CXL30SC and CXL 40SC

The anode (+) terminal is 9.5mm diameter with a cable attached for connection to the igniter. The cathode (-) terminal is 8.0mm diameter.

LAMPING.

Remove all electrical power from the fixture by turning off the 50A circuit breaker on the power tray or by turning off the wall disconnect switch.

Remove the lamp house top cover by undoing the six security screws using the special torx wrench provided with each follow spot.

The rear lamp holder has an adjustable plate which is secured down with four screws. If you are using the spotlight as a 3KW the plate needs to be in the forward position and it would need to be in the rear position if you use a 4KW lamp. If you need to adjust the plate you need to loosen the four screws, two on either side, and slide the plate to the forward position or the rear position along the track and into the notch and tighten the screws back down to lock it in place.

Tilt the front lamp support forward. Cut the ignite assist wire off of the bulb if it is attached to the Anode of the lamp.

Standing on the right hand side of the lamp house, and holding the xenon lamp (+ve) terminal in the left hand, insert the (-ve) terminal through the hole in the rear of the reflector. Bring the front lamp holder up to meet the lamp and insert the terminal into the front lamp holder block. Do not tighten the two screws at this time. Insert the (+ve) terminal into the rear lamp holder insulator / collar.

Loosen the top knob on the rear lamp holder and move it down and all the way to the left so you maintain full lamp adjustment for the hot spot.

Attach the (+ve) electrode wire to the **top** 3/8" diameter stud on the red igniter labeled (+) lamp out. Secure with the 3/8 nut and lock washer at a five O'clock position looking at it from the left side. Tighten the nut with a 9/16" wrench ensuring that the lug remains away from any grounded metal.

Rotate the lamp counterclockwise to take up the slack on the (+VE) braided wire with the lamp.

IMPORTANT. LAMP LEAD MUST NOT COME CLOSER THAN ONE INCH FROM ANY METAL PART (other than lamp end) OR ARC-OVER WILL OCCUR.

Assure lamp (-ve) terminal is fully seated in the front lamp holder and tighten the two socket cap screws evenly with a 5/32" Allen key. As a final check make sure all lamp fittings and connections are tight and that the cable is correctly routed away from chassis metalwork. Also make sure that any tools or other loose items are not in the lamp house and that nothing has fallen into the blower.

Tighten the rear collar screw when the terminal is fully seated in the (+ve) rear lamp holder with a 7/64" Allen key.

There are two small holes on the rear partition that line up with the two holes on the rear lamp holder. Use a small Allen key to slide through them to align the lamp close to center.

Replace the lamp house top cover with the top exhaust vent towards the rear of the fixture. (The holes will not align if reversed.) Fasten using **ONLY** the security screws and special torx wrench provided.

Open rear door. Turn the bottom knob clockwise to get a hot spot and then loosen the top adjustment knob enough that the knob can be moved and center the hot spot. Tighten the knob when you get the hot spot in the center of the beam and then turn the bottom knob counter clockwise to flatten out the beam. Close the rear door.

DE-LAMPING

When the lamp needs to be removed or rotated longitudinally, use the following procedure.

Remove all electrical power from the fixture by turning off the 50A circuit breaker on the power tray or by turning off the wall disconnect switch.

Prepare the xenon lamp protective container provided by the lamp manufacturer.

Always wear protective gear to handle Xenon bulbs.

Remove the lamp house top cover by undoing the six security screws using the special torx wrench provided with each follow spot.

Using a 9/16" wrench, disconnect the lamp cable from the (+) lamp out terminal of the igniter. Allow the cable to hang freely but do not allow the cable to hit the lamp glass in any way.

Loosen the socket cap screw on the collar of the rear lamp support.

Loosen the two socket cap screws evenly on the front lamp support block.

Holding the negative terminal (front) in the right hand, ease the positive terminal (rear) out of the collar keeping hold of the lamp at both ends at all times.

With the right hand ease the negative terminal out of the front support block.

Using the left hand gently pull the lamp out from the back of the reflector.

IF THE TERMINAL APPEARS TO BE STUCK, IT MUST BE LOOSENED. DO NOT USE EXCESSIVE FORCE TO PULL OR TWIST THE LAMP TO FREE IT.

AVOID THE LAMP GLASS FROM HITTING THE EDGES OF THE REFLECTOR AS IT IS REMOVED FROM THE LAMPHOUSE.

A soft cloth may be used.

Lay the lamp carefully in its protective container and secure it closed.

If the lamp is being removed for transportation, make sure that the front and rear lamp terminal screws are tightened and place the 3/8" nut and washers back onto the igniter and tighten.

FIXTURE ILLUMINATION

This section assumes that the lamp has been correctly installed as in the previous section and that all covers are fitted and that the electrical supply is correct and switched on.

The 50A circuit breaker adjacent to the input cable should be set to the “ON” position. The breaker is located at the bottom rear of the electronic ballast. The smaller circuit breaker cannot be manually switched off, but should remain in the ‘pushed in’ state.

At the instant of circuit breaker switch-on, the main lamp house blower, the iris fan and the color-changer fans should be heard or felt to be running.

Underneath the ammeter is the lamp current control. Rotate the control fully counterclockwise. This will set the lamp current to approximately 94A. If running the 4KW lamp then set the current control pot fully clockwise to get it around 135A.

On the front of the electronic ballast are two momentary-action push-button switches. The bottom amber colored switch should be illuminated, indicating the STANDBY condition.

To start the fixture, momentarily depress the red “ON” switch. The switch will illuminate red signifying an “ON” condition. After approximately 5 seconds the xenon lamp will strike and emit continuous light. The ammeter on the electronic ballast will indicate a value depending on where you set it and the indicating hours meter located on the rear of the fixture shall start counting, indicated by a pulsating dot on the display panel.

Once the lamp has been started it should remain operating for a minimum period of 30 minutes as recommended by all of the xenon lamp manufacturers. Short on /off periods will drastically shorten the lamp life and cause increasingly harder restrikes.

Once the lamp has been running for 10 minutes, adjust the lamp current control until the desired current is achieved. A small blind grommet is provided to prevent inadvertent adjustment of this control once it has been set.

Should the lamp fail to start or unexpectedly extinguish, please refer to appendix A.

LAMP OPTICAL ALIGNMENT.

With the fixture iris, fader and chopping shutter wide open, open the rear door of the lamp house and rotate the bottom FIELD knob clockwise to obtain a ‘hot spot’ within the circle projected on a wall. This knob adjusts the xenon lamp in and out of the reflector.

Loosen the top knob and by moving the knob around adjust the hot spot so that it is central within the main circle. Tighten the knob. Readjust the bottom FIELD knob until the desired field flatness is reached. It is considered acceptable that this FIELD control is adjusted when using smaller iris apertures to obtain a brighter spot by peaking the field. Taking the field control beyond flat will reduce the light output and may be used to balance light levels with other brand 3KW xenon fixtures.

The lamp house rear door should remain closed except when adjustments are being made.

(If the desired optical alignment cannot be achieved using the above procedure, a more detailed alignment is described in Appendix B. This is the procedure used when setting up a new fixture at the factory.)

LAMP LIFE

For the best lamp life, it is recommended by all xenon lamp manufacturers, that the lamp is left running for periods not less than 30 minutes. During the normal life of the 3kW lamp (approx 2200 hours) it is also recommended that the lamp is rotated 180 degrees after 500 hours accumulated use. During operation of the 4KW lamp it is recommended that it is rotated 180 degrees after 500 hours accumulated use. This prevents a concentration of lamp blackening and fatigue just at the top of the lamp globe. The lamp naturally darkens with age due to vaporization of the tungsten electrodes.

COLOR BOOMERANG / COLOR CHANGER

A six color boomerang is included with the spotlight. Inserting one color into the beam will release a previously inserted color or all colors . Depressing the release lever tab will also release all colors. Several colors may be inserted simultaneously. The color frames are accessible through the color boom access door. Colored gels or dichroics may be used.

Note: Industry standard 9" frames are used and are interchangeable with frames used by touring shows.

EFFECTS DIPSTICK SLOT

Just behind the color boomerang is an effects dipstick slot which may be used for a fixed filter ie; diffusion, color correction or UV. A two filter dipstick is provided.

FIXTURE BALANCING

The fixture is set at the factory for correct tilt balance with the front lens forward. There is a sliding weight in the front bottom section of the fixture. The position may be adjusted by a knob under the front belly pan to maintain balance.

The yoke brackets mount to the main chassis through slotted holes. To provide further balancing, if dichroics or sighting attachments are used, loosen the four socket cap

screws on each yoke bracket and move the bracket to the desired location. Ensure that both yoke brackets are adjusted equally. Retighten the screws. Access holes are provided in the brake disks for long T-handled Allen wrenches.

REPLACEMENT OF THE TIMER BATTERY

The timer battery lifetime is nominally four years as specified by the timer manufacturer. When the battery reaches the end of its life, the timer will cease to display the time.

The timer is accessible after removal of the four Allen screws that hold the timer to the blower box and then remove blower housing box underneath the lamp house.

On the back of the timer is a small plastic cover clipped in place. Push the clips and the cover can be removed, exposing the battery. If the battery is replaced within a few minutes from removing the cover, the time previously accumulated will remain, assuming the batteries were not totally dead. Replace the timer rear cover ensuring the clips snap lock and then reinsert the timer and panel into the power tray. Fasten with the four screws.

The replacement battery is a ½ AA. (Lithium). 3.6V
Dimensions 14.5mm Diameter X 25mm long

Saft LS 14250

Tadiran TL-5101

2011- FEB -10

APPENDIX A

If the fixture fails to illuminate the following diagnostic guide may help.

- 1) Fans not heard or felt to start when the 50A circuit breaker is switched on.
Check that the supply voltage to the fixture is present and correct.
- 2) Amber STANDBY switch is not illuminated.
The safety switch, the airflow switch (or air pressure switch on later models) is not operating. Check connections to all switches. If the power tray has been removed and reinstalled, check that all internal connectors are fully seated.
- 3) After pressing the ON switch, the fixture will flash up to three times but will not stay on continuously.
 - a) Incorrect lamp installation.
 - b) Xenon lamp is faulty.
 - c) Lamp life is getting near end.
 - d) Lamp has been abused by repeatedly trying to restrike the lamp, not allowing the lamp to cool correctly.
 - e) Power supply failure.
- 4) After pressing the ON switch, the xenon lamp illuminates but is unstable, flickers and may finally extinguish.
 - a) Faulty xenon lamp, well used and abused possibly by repeated attempts to restrike it, or more usually, short on times, or switching off the cooling (via the circuit breaker) before the lamp has cooled sufficiently.
 - b) Faulty lamp connections, make sure all connections are tight.
 - c) High fixture angle upwards. Reduce angle to more horizontal position. Use front mounted mirror if high upward angles are necessary.
- 5) Fixture extinguishes after running for some time, but red ON switch is still illuminating. Fixture restarts with no further problem.
 - a) Check lamp connections.
- 6) Fixture extinguishes after running for some time, amber STANDBY lamp is illuminating, red ON switch is not lit.
 - a) Intermittent safety switch, airflow switch, air pressure switch.
 - b) Lamp house cooling blower faulty or air flow restricted, causing operation of airflow or air pressure switch.
 - c) If an exhaust duct is used, sudden changes in pressure may cause the air pressure switch to briefly open.

APPENDIX B

Optical set up & alignment sequence for the Model 1295 follow spot.

1. Before the lamp is installed, ensure that the reflector mounting plate is square with the lamp house sides.
2. Set the rear lamp adjuster so that the xy adjusting knob is in the center of its range of travel.
3. Set the Z axis (field) knob so that the inner rear lamp adjusting plate is parallel to the outer plate.
4. Install the lamp, using all precautions necessary.
5. Adjust the iris plate so that the adjusting slots are centered on the mounting studs and that the plate is centered from side to side. Verify that the iris plate is vertical by using a square against the horizontal flat plate to which the iris plate is mounted.
6. Using the square against the left hand front guide rod verify that the fader plate is vertical.
7. Using the square against the chassis side, adjust and set the rear moving lens so that it is vertical.
8. Install the lamp and switch on. The fader, chopping shutter and iris should be open. The front lens should be all the way forward, adjust the focus for a sharp image.
9. Imagine that the iris is not present or ignore the circle that the iris creates for now.
10. By pulling and rotating the field knob, create a hot spot on the wall such that there appears to be a halo around the hotspot. The knob will be adjusted further back than would occur during normal operation.
11. Loosen and adjust the xy knob until the hotspot appears to be centered in a halo. This centered hotspot does not have to be in the center of the circle created by the iris. If the image appears to be non circular then further adjustment is required.

12. Adjust the field knob to flatten the field and allow the halo diameter to be just smaller than the iris circle diameter even if they do not overlap.
13. Adjust the position of the iris plate so that the iris circle is coincident with the light/halo circle. Lock the iris plate. By pulling back on the field knob the halo can be rapidly changed in diameter to verify that the iris is centered on the halo.
14. Adjust the field knob so that the diameter of the halo and the iris are the same diameter. This will result in the brightest and flattest field. If the halo does not appear to be round, it may be that the reflector shape is distorted.
15. Adjust the rear lens up and down and sideways, while keeping it vertical, until the light circle is centered on the fader plate. A perfect adjustment will result in no light being visible on the fader plate, or possibly a circle that is equal width around the edge of the fader plate aperture. Lock the lens adjustment screws.
16. A circle of light will be seen on the front lens and should ideally be centered, although due to a small misalignment of the reflector it could be off center by about one inch. This is acceptable.
(In order to make it centered, without adjusting the reflector, will require repositioning the iris until it is. The field would then have to be flattened further to fill the iris circle. This greatly reduces the intensity of the image.)
17. Adjust the focus and iris to verify that the image is clean, flat and sharp over all possible positions of the front lens. If necessary repeat this procedure from step 10.
18. The optical system is now set up correctly.

2011-FEB-10

PARTS MANUAL

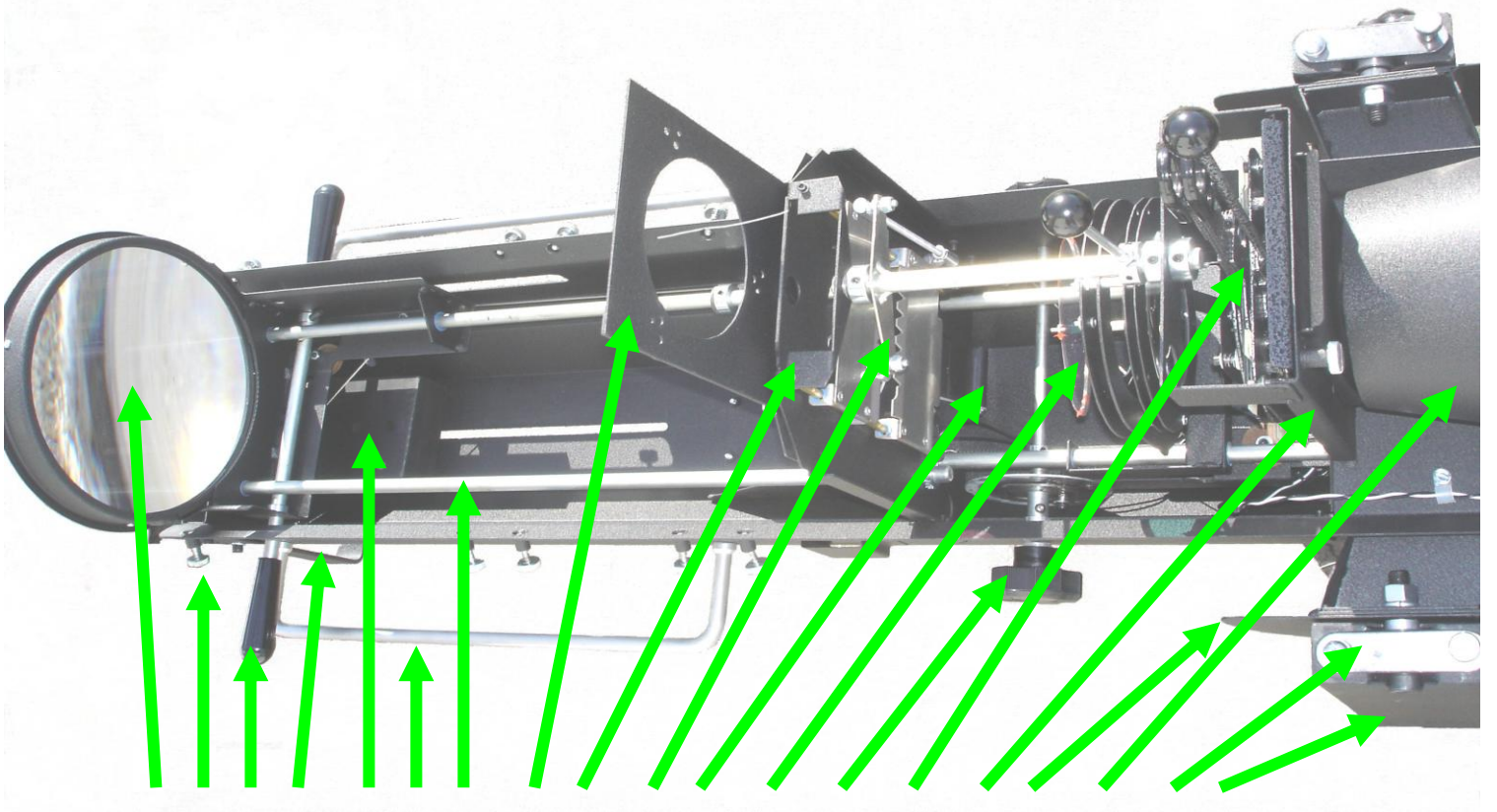

- 1
- 2
- 3
- 4
- 5
- 6
- 7
- 8
- 9
- 10
- 11
- 12
- 13
- 14
- 15
- 16
- 17
- 18
- 19

Item #	Description	Part #
1.	10" X 39" Front Lens	12999
2.	Housing Fastener Kit	126659
3.	Follow Handle W/ Set Screw	35020D
4.	Front Bale	129092
5.	1295 Counterweight With Knob	129582
6.	18" Aluminum Handle	273
7.	27.25" Front Guide Rod	129098
8.	Effects Dipstick	1313
9.	Fader Mid-Plate Assembly	129051X
9.1	Three Blade Fader Assembly	129585X
	8-3/4" Brass Rod 1/4" Diam.	289
	Ball Joint	210
10.	Upper Fader Blade	1290117
11.	Lower Fader Blade	1290116
12.	4-1/2" Heat Filter assembly	1295499
	Heat Filter Glass Only	4991
13.	2-1/2" Female Knob W/ Set Screw	35022X
14.	Gate Magazine	1825
15.	Gate Magazine Holder	129556
16.	Yoke Mount Left	129121L
	Yoke Mount Right	129121R
17.	Light Cone	129109S
18.	Yoke Hold Down Clip W/ Fastener	13224
19.	Tall Yoke Assembly	13229X

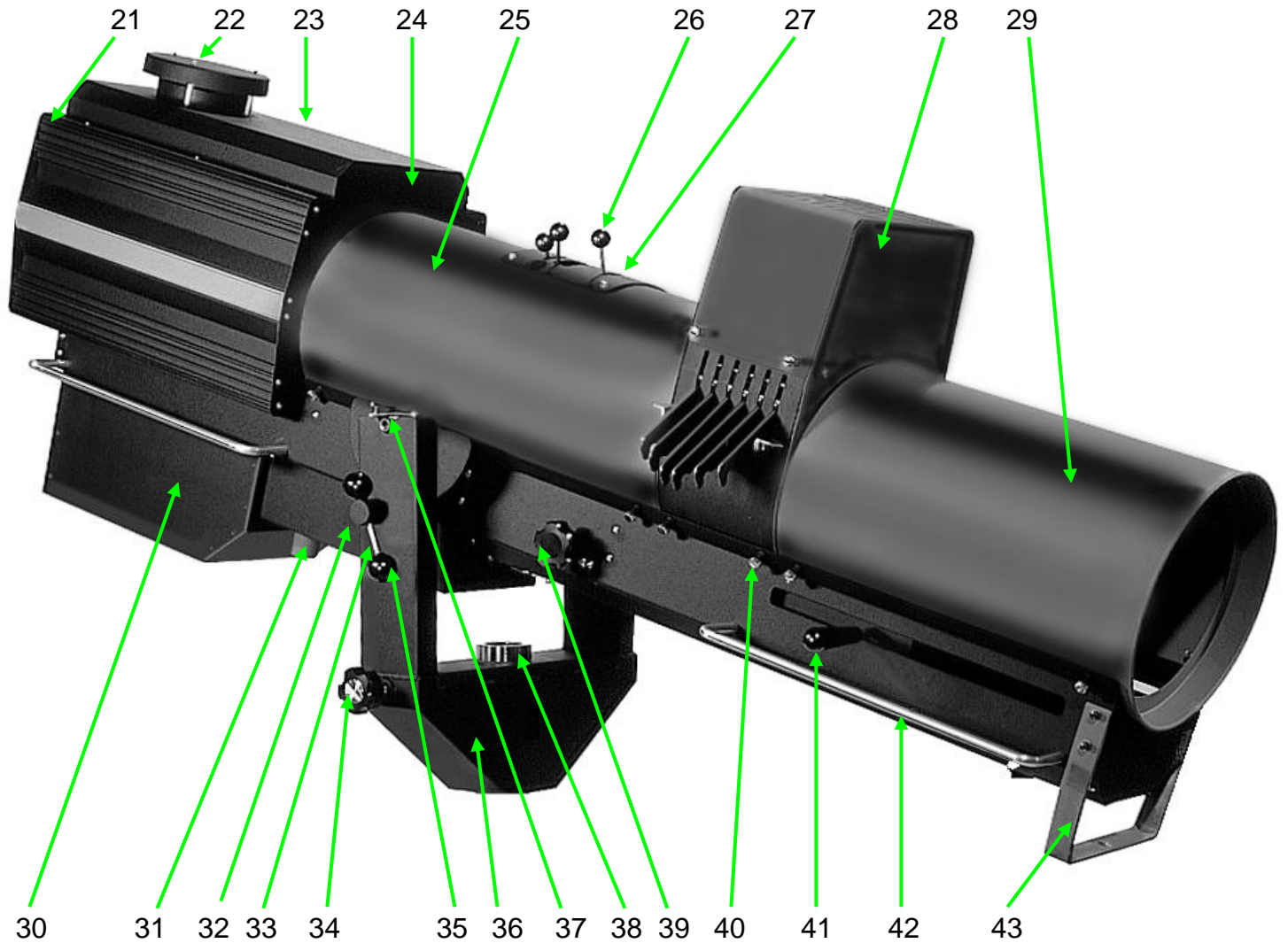

Item #	Description	Part #
21.	Upper Right Extrusion	1295120H
	Lower Right Extrusion	1295122H
	Upper Left Extrusion	1295119H
	Lower Left Extrusion	1295121H
22.	Vent Cap W/ Mounting Hardware	127514
	Vent Cap Hardware Kit	129118X

23.	Lamp house Top Assembly	12951X
Item #	Description	Part #
24.	Front Lamp house Partition	1293100
25.	Rear Cowling	129563
26.	1" Ball Knob	120659
27.	Aperture Cover	129525
28.	Color Boom Assembly	129038XB
	Color Box Assembly	1290385XB
	Color Changer Assembly	1290381XB
	9" Color Frame W/ Channel	1278110X
	9" Color Frame Ring Only	1278110
29.	Front Cowling	129562
30.	Blower Box	1295114
31.	Black Cam Lock Connector	452-B
	Red Cam Lock Connector	452-R
32.	Brake and Handle Assembly 2 Shoes	132213X
33.	4-1/4" Handle Stud	4373
34.	2-1/2" 5pt. Knob Male 3/8"	120628
35.	1-1/2" Ball Knob	126629
36.	Tall Yoke Assembly	13229X
37.	Yoke Hold Down Clip W/ South co	13224
38.	2" Collar	306
39.	2-1/2" 5 Pt. Knob Female 3/8"	35022
40.	Housing Fastener Kit	126659
41.	Follow Handle W/ Set Screw	35020D
42.	18" Aluminum Handle	273
43.	Front Bale	129092

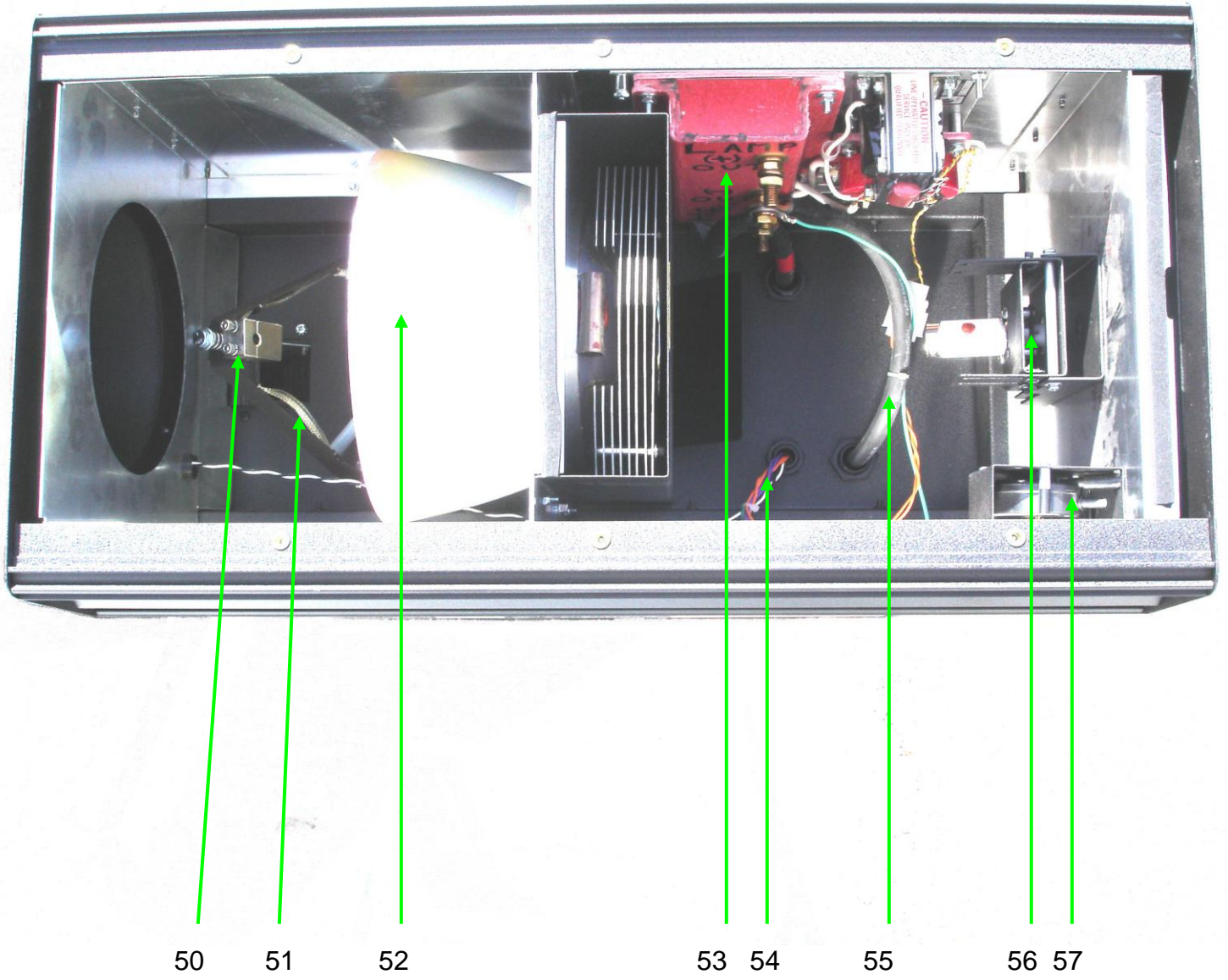

Item #	Description	Part #
50.	Front Lamp Contact Assembly	1294179
51.	Front Lamp Lead	129437X
52.	10" Finned Reflector W/ Magnet	129325
53.	Igniter Assembly	932
	80 Amp Pulse Transformer	9325X
	High Voltage Transformer	9259
	Adjustable Spark Gap	1327
54.	Metric Cable Strain Relief	469
55.	Negative 1/0 Cable Assembly	129558-
	Positive 1/0 Cable Assembly	129558
56.	Rear Lamp Holder Assembly	129515X
	Rear Lamp Insulator Assembly	1295151
57.	Pressure Switch Assembly	441X
	Switch only	89-45